



**CHINA<sup>2</sup>WEST SERVICES<sup>TM</sup>**

Quality Manufacturing Solutions



# 01

## Who we are

- 02 C2W Profile
- 03 Our Story

Our Story

# 04

## Our Services

- 05. Supply Chain Management Services
- 06. Procurement Services
- 07. Supplier Verification Services
- 08. Manufacturing Services
- 09. Our Manufacturing Expertise
- 20. Prototyping Services
- 21. Product Development Services
- 22. Product Development Process
- 30. Quality Control & Assurance Services
- 31. Quality Control and Audits
- 34. Logistic Services
- 36. Other Services
- 37. Business Setup Services

# 38

## C2W Global Distribution

# 39

## Who we work with

# 40

## C2W Group 41. The Companies

## Who we are

China 2 West is the world's leading China based Supply Chain Management, Quality control and product development company.

Western owned and managed with over a decade of trading history, C2W is a one-stop shop incorporating design, development, prototyping, tooling, production, quality control, certification and logistics.

Our core capabilities lie in delivering a complete supply solution for Chinese manufactured products to be suitable for Western markets. Our uniqueness is being able to offer solutions from any point in the development chain including those that are just a mere concept.

Our greatest assets are our on the ground presence, network of trusted suppliers and wide ranging experience in a vast array of different products and manufacturing processes.

During the last decade we have helped many Global companies to move their production to China with the minimum of disruption to their business. With a growing team of engineers in many different technical fields we are confident that no product is out of our range of capabilities.

### Our Mission

“To provide supply chain management, supplier verification, quality control, manufacturing consultancy and product development services to companies that need a reliable and risk free supply of goods from China.

# Our Advantage Is Yours

## C2W Profile



Global HQ

Zhuhai, Guangdong, PRC

Global Sales HQ

Freeport, Grand Bahama, Bahamas



China  
Locations **13**



Global Sales  
& Support Offices **8**



Number of Employees  
Global **65**



C2W Certified  
Suppliers **356**

EST. 14 th July  
2005

Hong Kong Incorporation  
14th July 2005

CHINA Incorporation  
27th August 2008

# Our Story

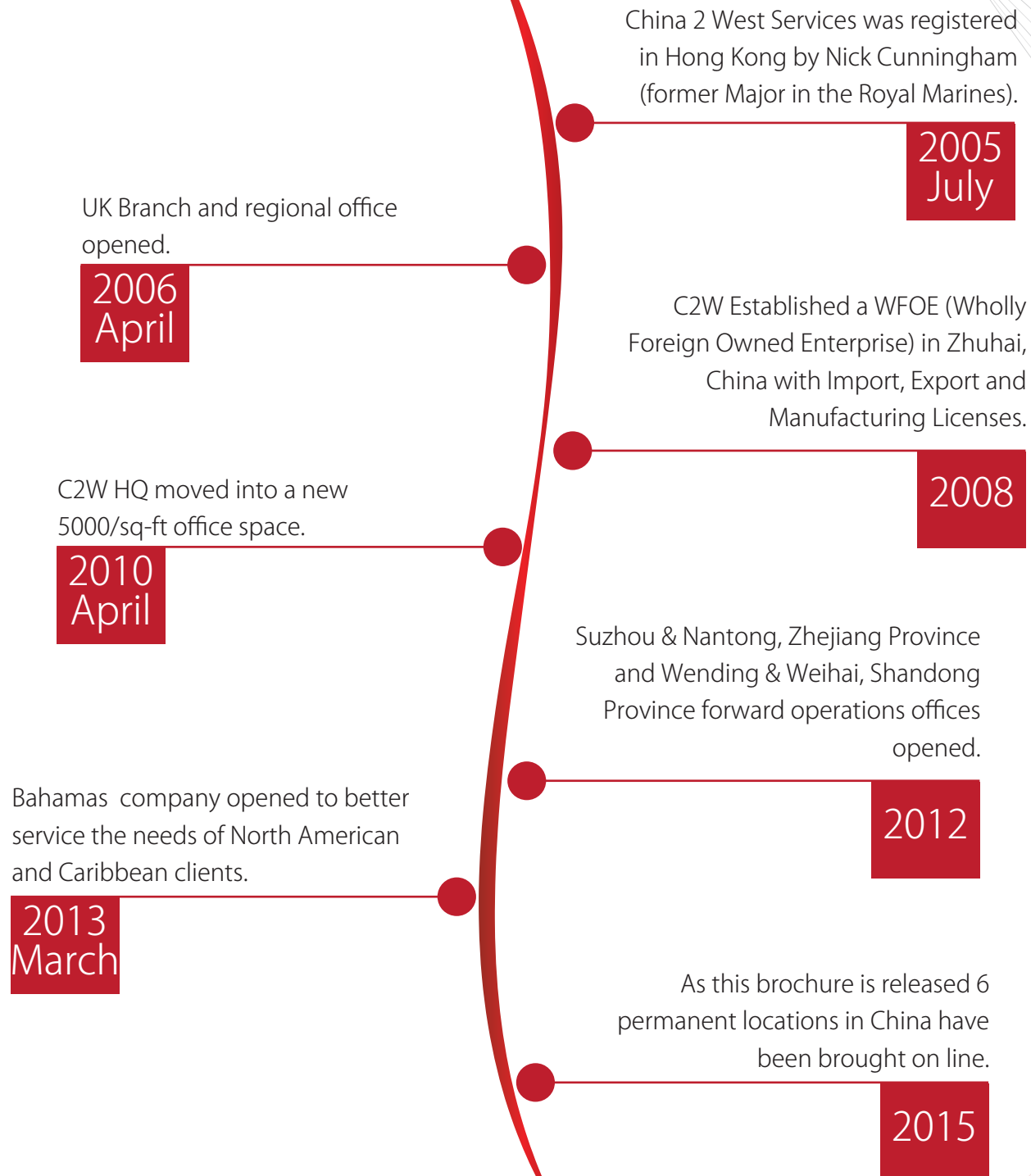

# Our Services

China 2 West offers a comprehensive range of services for the purpose of turning concept ideas into real products in the fastest possible time.

Every product passes through a sequence to become reality starting from concept through design, drawings, prototyping, tooling, mass production, quality control and logistics.

At C2W we can assist you in every stage of the process or simply plug into the development chain at any point.

While being western managed, our permanent location in China and use of Chinese expertise wherever possible ensures far greater efficiency and lower cost than western based alternatives.

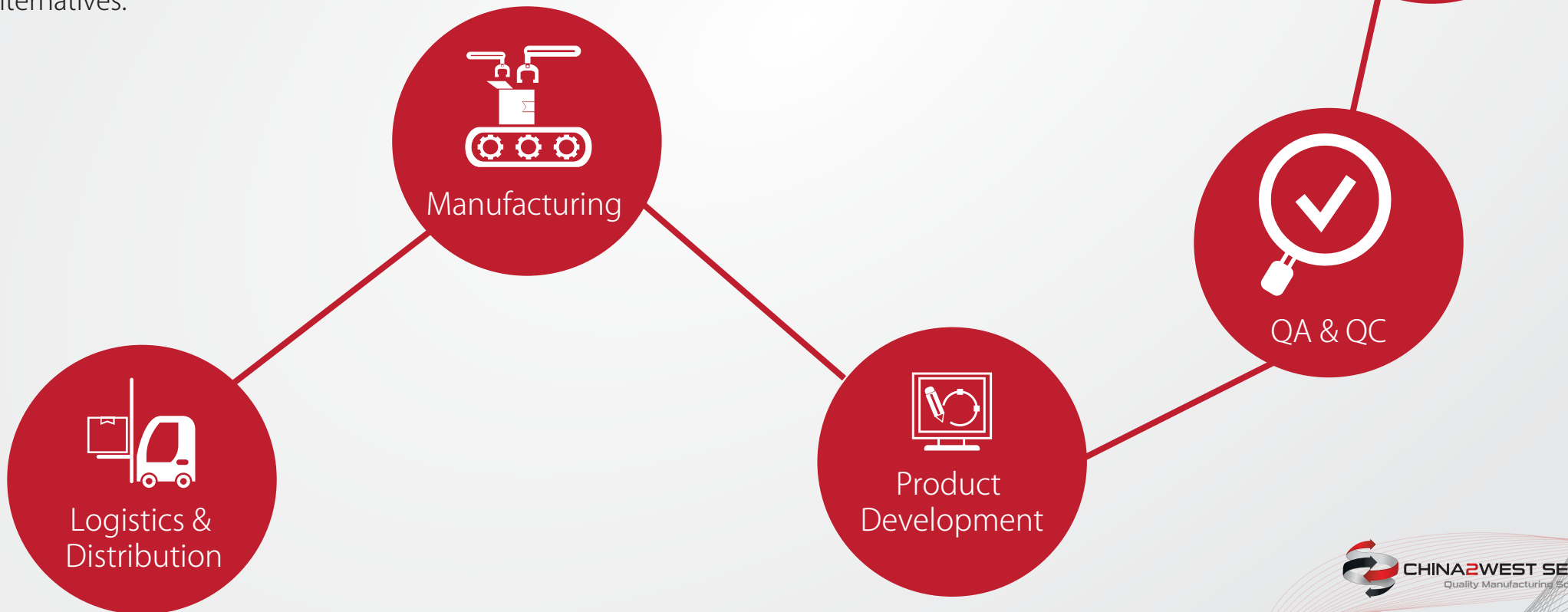

# Supply Chain Management Services

Our manufacturing team is drawn from a wide range of engineering disciplines. We have extensive experience in plastics, metals, composites, electronics, paper products and textiles. We assess each project and select the most suitable facility based on quantities and target prices. We then work with that factory undertaking a full project management service and reporting to our customers of progress and problems. Manufacture of any product will never be plain sailing, but we know that most problems can be solved with good communication.

From being based in China's manufacturing hub of the Pearl River Delta in Guangdong since 2005 and having extensive time in and operatives based around the country we have been able to build a robust list of 'trusted facilities' that have been audited both socially and with quality in mind by our engineers. These facilities have had their processes improved by us and have experience in working with us. Through these facilities we have no doubt that we can assist you in having your manufacturing moved to China or within China to improve quality or save cost.

Quite simply, you speak to us in your language and we speak to the factory in Chinese!

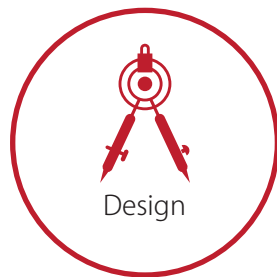



# Procurement Services

Sourcing from the Far East can be a risky business. Finding a reliable supplier is the first problem, with only a website to look at, it is impossible to know if you are dealing with a state of the art factory or a back street sweat shop. Our sourcing team will select and assess the most suitable supplier to meet your needs. We ensure your requirements are understood and weed out the unsuitable or incapable. We will then monitor and inspect to ensure that the quality of production items actually matches samples.

When you use C2W, you will have your own experienced team in China, who will oversee your order and ensure you avoid the common pitfalls of low quality goods, poor communication and unexplained delivery delays.

We understand the QPS equation – Quality, Price, Speed: From experience we know that without ‘eyes and ears’ on the ground you will be doing very well to achieve two variables in the QPS mix. We are here to ensure all three are met first time.

We have a database of established suppliers we know to be reliable and will use the information you provide to find which company best suits the criteria you have set. Within a short space of time we are usually able to tell you the ability of suppliers to meet your needs and will send photos and samples for your evaluation.

Once samples have been approved we are able to arrange production and ensure quality control throughout the manufacturing process. Our ability to provide a constant presence on the ground provides an incentive to the manufacturer that is impossible to achieve from your home-base.



Procurement



# Supplier Verification Services



With a diverse network of in-house certified suppliers and extensive supply chain management expertise gained over the past decade of operation C2W is able to offer our clients risk free China based supply choices in virtually every major manufacturing sector.

# Manufacturing Services

Since 2005 C2W has completed over 2,500 manufacturing projects. Our strong team of engineers from different disciplines and our ability to learn new technologies quickly, has given us an unique advantage over our competitors.

The expertise gained enables C2W to offer its customers reliable supplier choices in virtually every major manufacturing sector.

Displayed below there's a list of products and processes that form part of our vast Manufacturing Expertise:

- Plastic Injection Molding
- Export Tooling
- Metalwork- Precision Stamping, CNC Machining, Extrusion, Die Casting, Forging...
- Electronics
- LED Lighting
- Solar and Environmental Friendly Lighting
- Textiles
- Promotional Products
- Printing and Packing
- Product Assembly
- POP and POS Displays



# Our Manufacturing Expertise

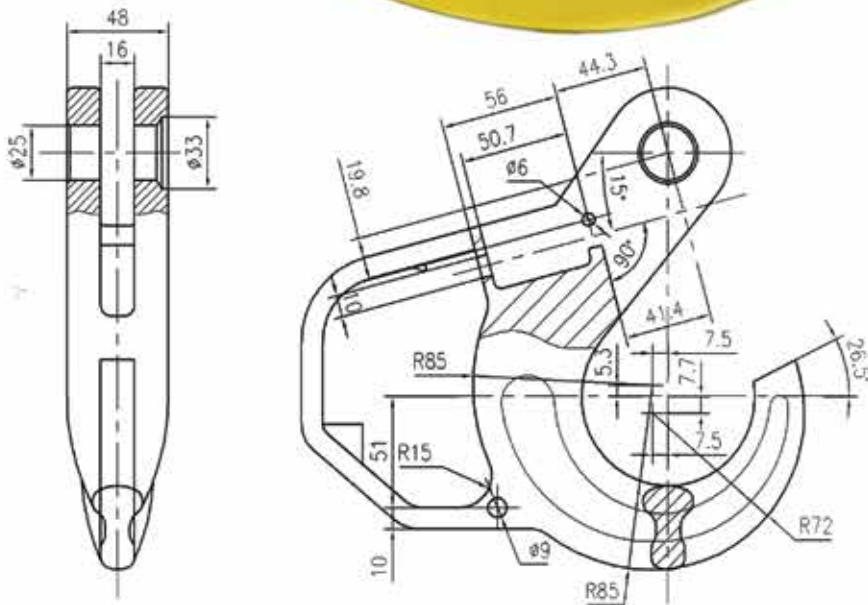

Forging

# Our Manufacturing Expertise

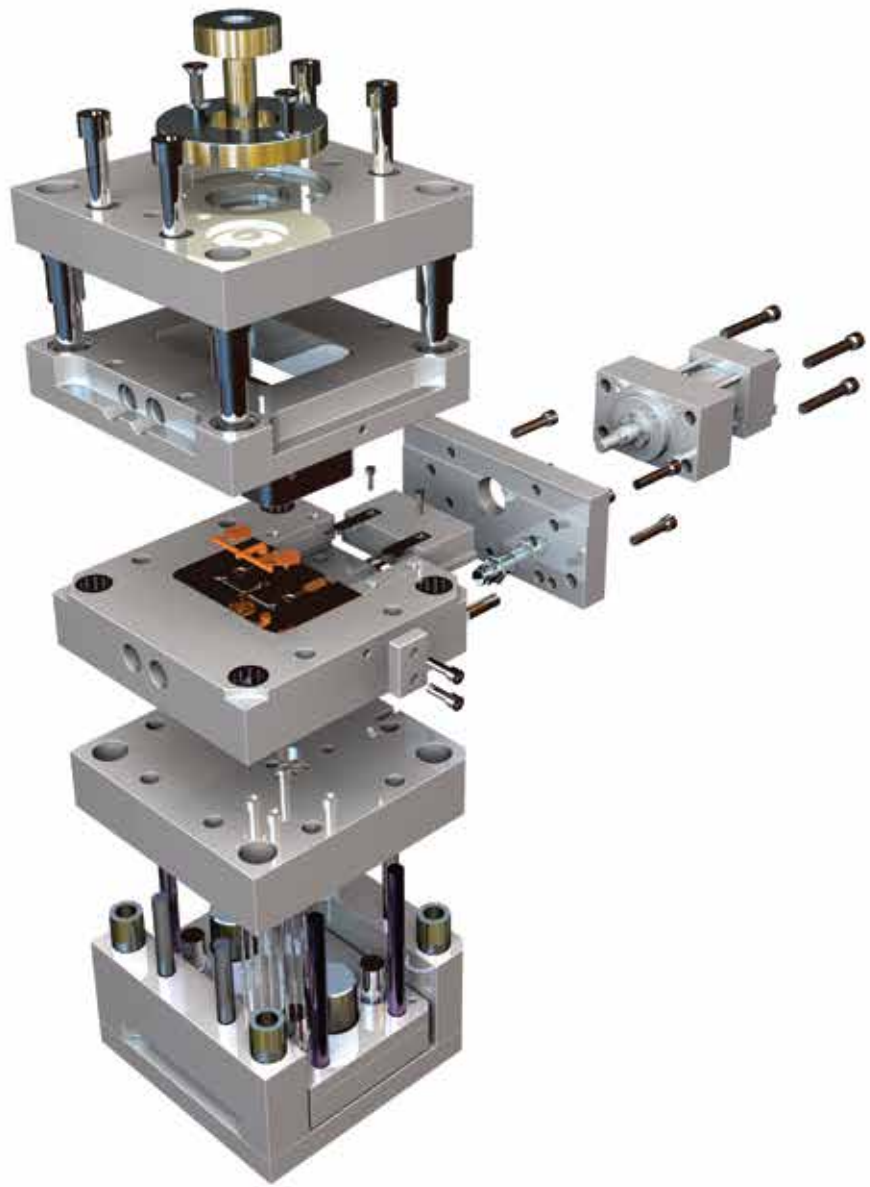

Injection Molding

# Our Manufacturing Expertise



Anodising/Electroplanting

## Our Manufacturing Expertise



Metal Stamping

# Our Manufacturing Expertise



POP & POS Displays



## Our Manufacturing Expertise



CNC Machining

## Our Manufacturing Expertise



Extrusions

# Our Manufacturing Expertise



Die Casting

## Our Manufacturing Expertise



LED Lighting

# Our Manufacturing Expertise



Solar Power kits

# Our Manufacturing Expertise



## Promotional Products

## Prototyping Services

China 2 West offers in-house prototyping services in China from our Zhuhai HQ. We have invested in American manufactured 3D printers allowing us the capability to print prototypes of up to 30cm cubed with a same day service. This is a great as a standalone service or to aid our engineers in general design work, DFM (design for manufacture) and fault finding.

In addition to this we've partnered with a local facility in Zhuhai allowing us to take advantage of a vast range of prototyping abilities, including: SLA and SLS Rapid Prototyping, Injection Molding, CNC Machining, Aluminium Tooling, Silicone and Rubber Molding, Clay Molding and even 3D Scanning/Printing.

Our C2W design engineers and industrial designers in China can use a range of engineering software including Solid Works, AutoCad, ProE and more meaning designs can not only be created but also edited and tweaked before and after printing of a prototype.

Contact us now for a very cost-effective prototyping in China quotation.

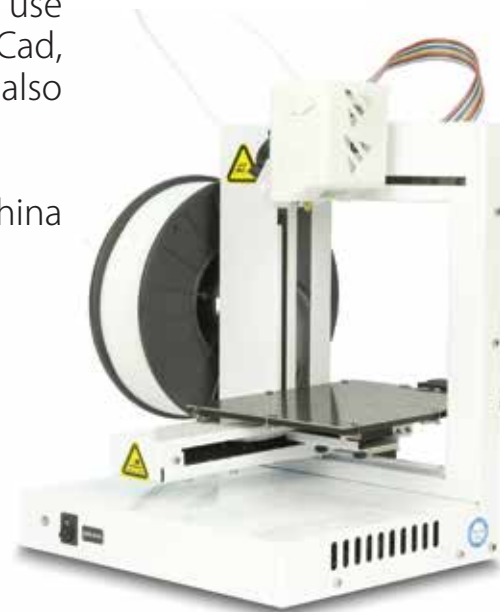

## Product Development Services

China 2 West offers Product Development services in China that include, Industrial Design, Electronic/Electrical Product Development and Technical Design Evaluation. These services are offered through of our in-house development department and engineering team.

We pride ourselves on the ability to take virtually any idea at any stage in its development, from concept to technical evaluation and providing the client a fully developed design regardless of its purpose while doing so at a fraction of the cost our western based rivals can offer.

Our team of experienced and multi-national designers and engineers can provide you with developed designs, product solutions, technical drawings and mold designs on a consultancy basis where you maintains full rights and ownership of the design and all information is subject to strict confidentiality agreements that cover not just China 2 West but also future potential manufacturers of the product after its development.

We have experience in designing plastic, rubber, textile, metal, electrical, electronic and wooden products as well as expertise in LED lighting and GPS tracking, showing a breadth of experience within the world's manufacturing hub that is hard to challenge.

If you have a great idea and some financial backing, contact us for some advice, a quotation and a possible feasibility study.

China 2 West's Product Development Services, Innovating Ideas.





# Product Development Process



Idea generation,  
Screening &  
Evaluation



Feasibility Study



Development



Testing



Market Launch

# Product Development Process

SIZES OF BAG:  
 small: ~~230~~ <sup>250</sup> x ~~240~~ <sup>190</sup> x 60  
 large: 280 x 250 x 60

UNFOLDED SIZE:  
 small: 480 x 230 x 30  
 large: 560 x 280 x 30

TRAY CONTENTS:  
 - 2X FOOD BOWL OF 110 Ø, STACKED ON TOP OF EACH OTHER.  
 - 2X 1 COMPARTMENT FOOD STORAGE BOX  
 small: 100 x 80 x 40  
 large: 140 x 100 x 40

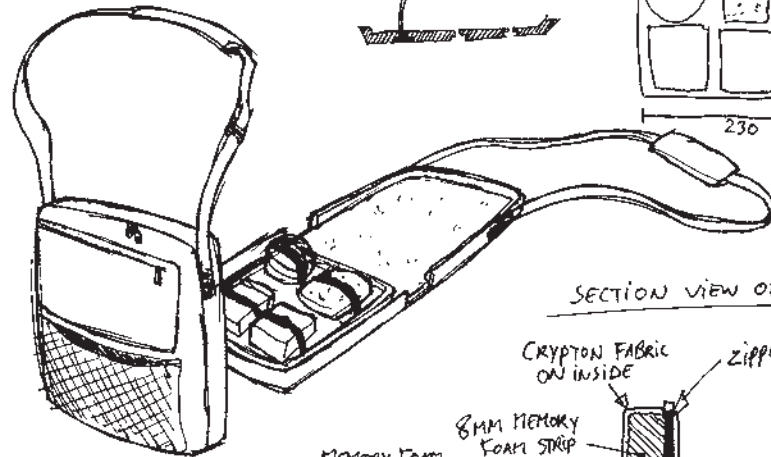
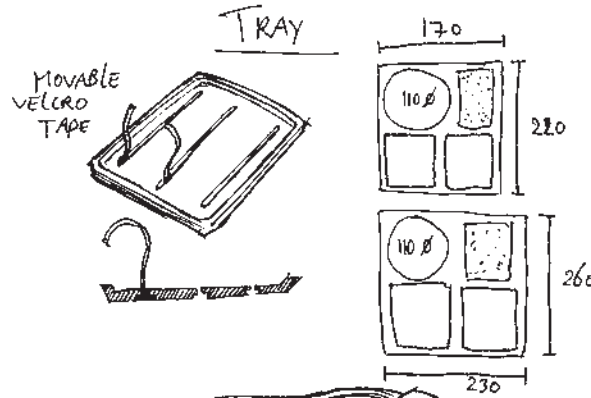

SECTION VIEW OF BAG:

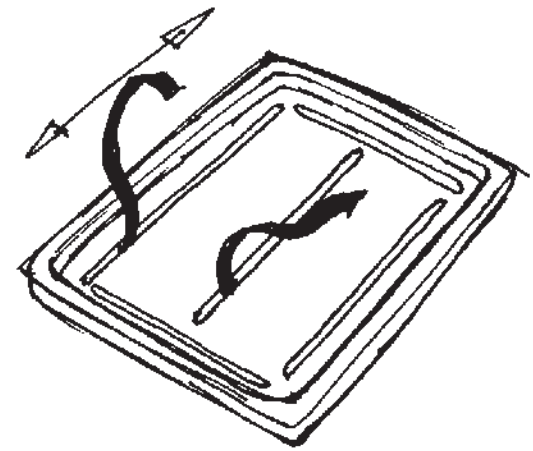
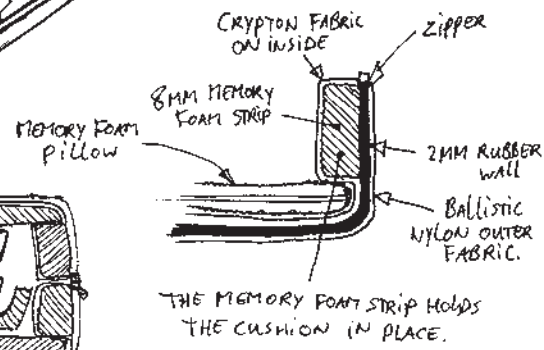

# Product Development Process

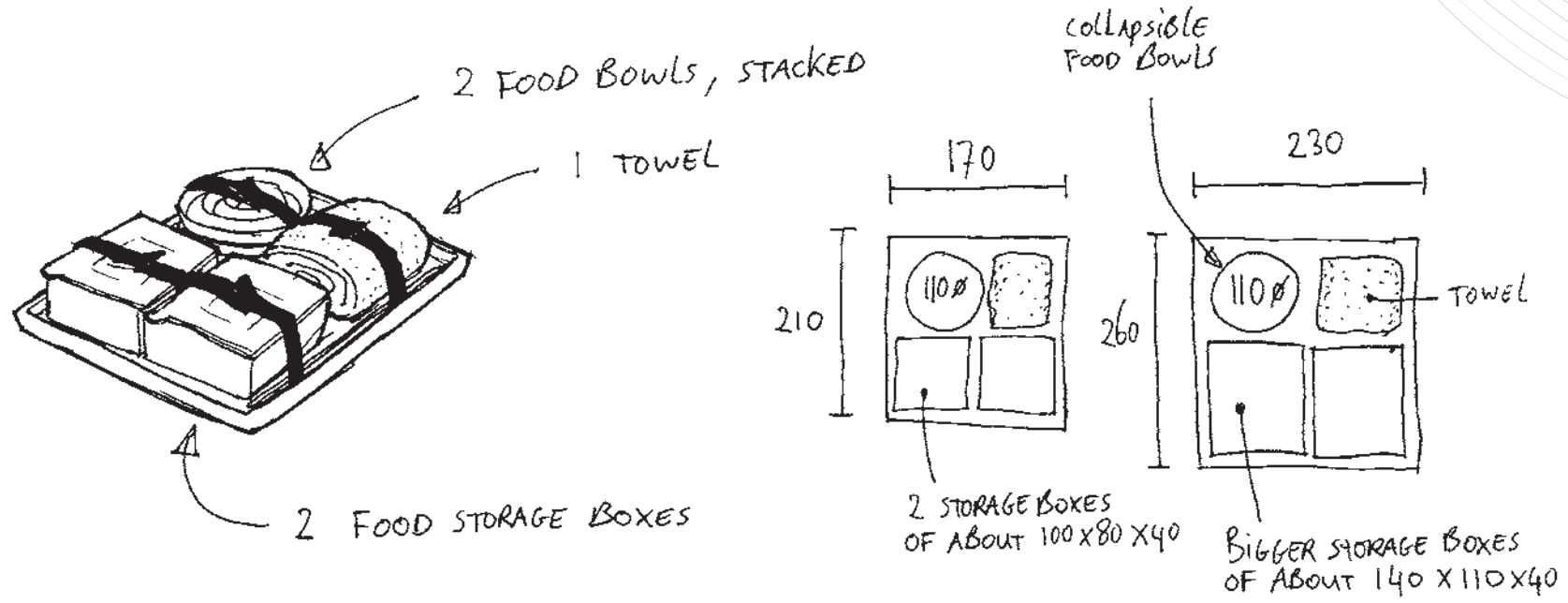

THE VELCRO TAPE IS MOVABLE THROUGH RAILS.

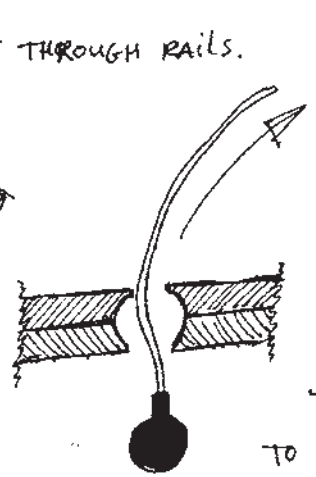
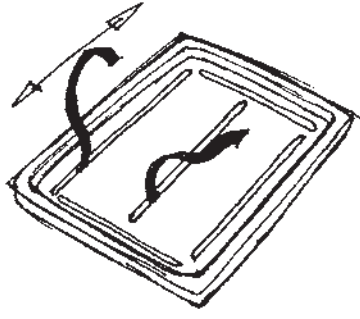

SECTION VIEW OF RAIL OF TRAY

THE VELCRO TAPE IS ATTACHED TO A PLASTIC PIECE THAT CONNECTS INTO THE RAIL THROUGH THE BOTTOM SIDE.

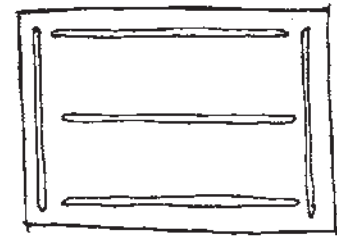

## Initial Sketching and Conceptualisation

# Product Development Process

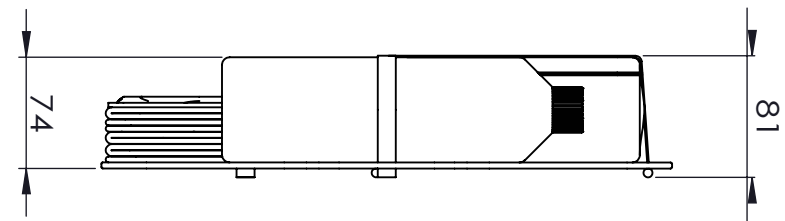
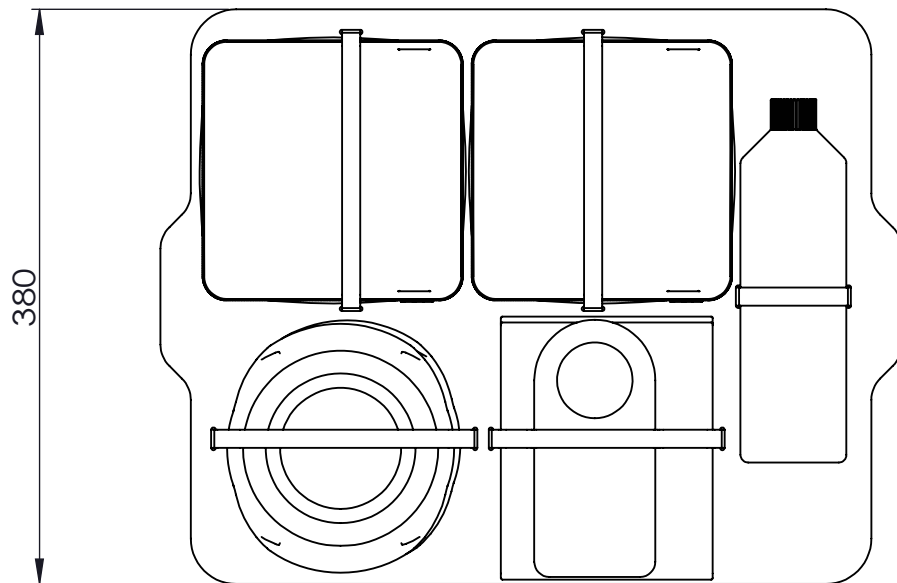
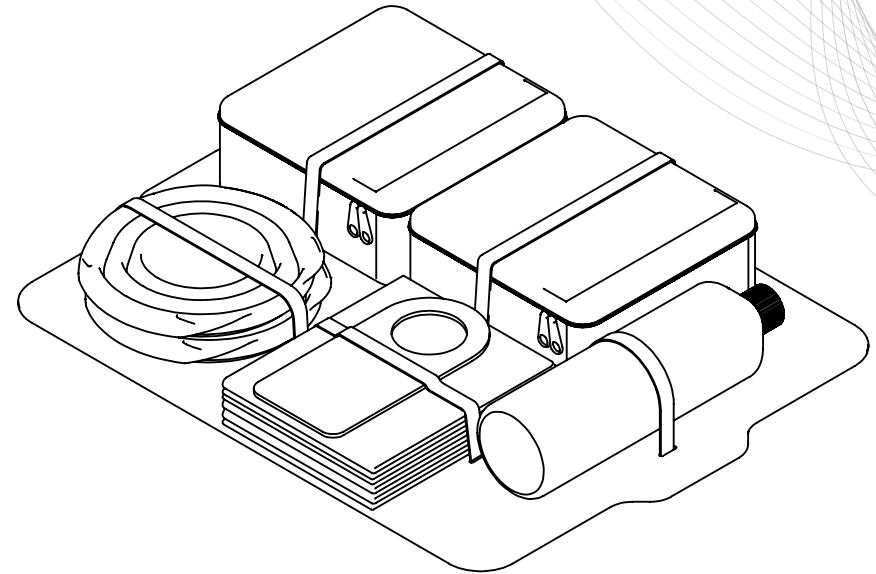
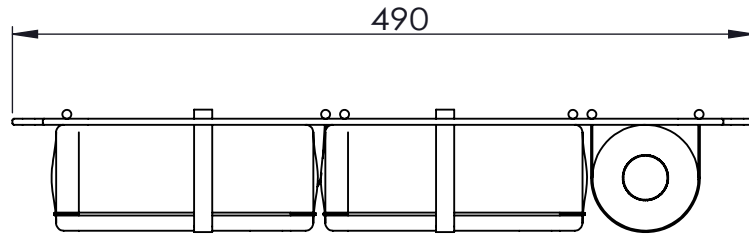

Technical Drawing Development

# Product Development Process

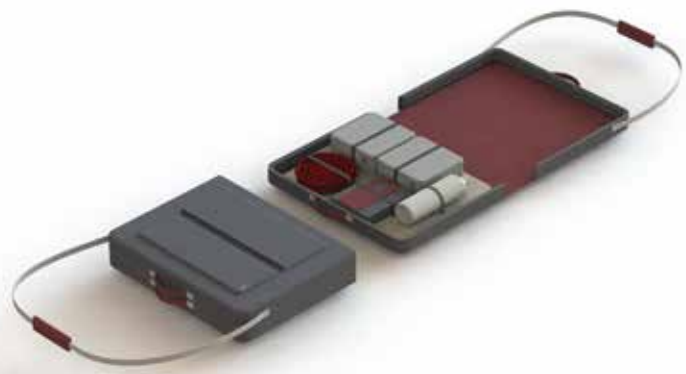
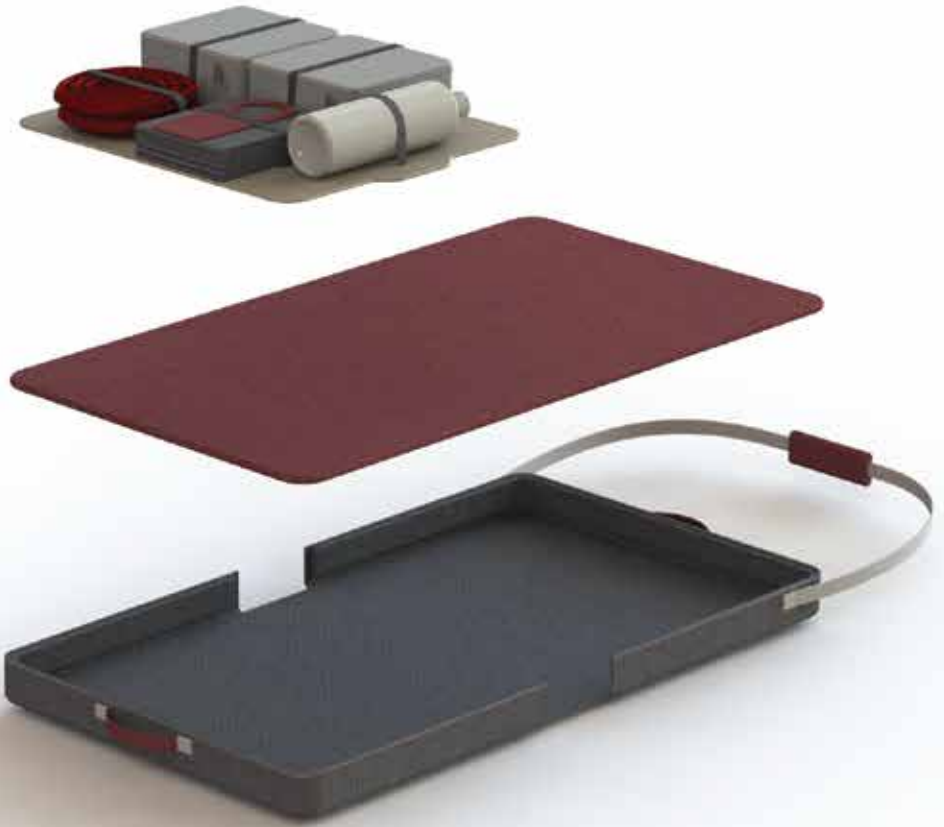

3D Rendering

# Product Development Process

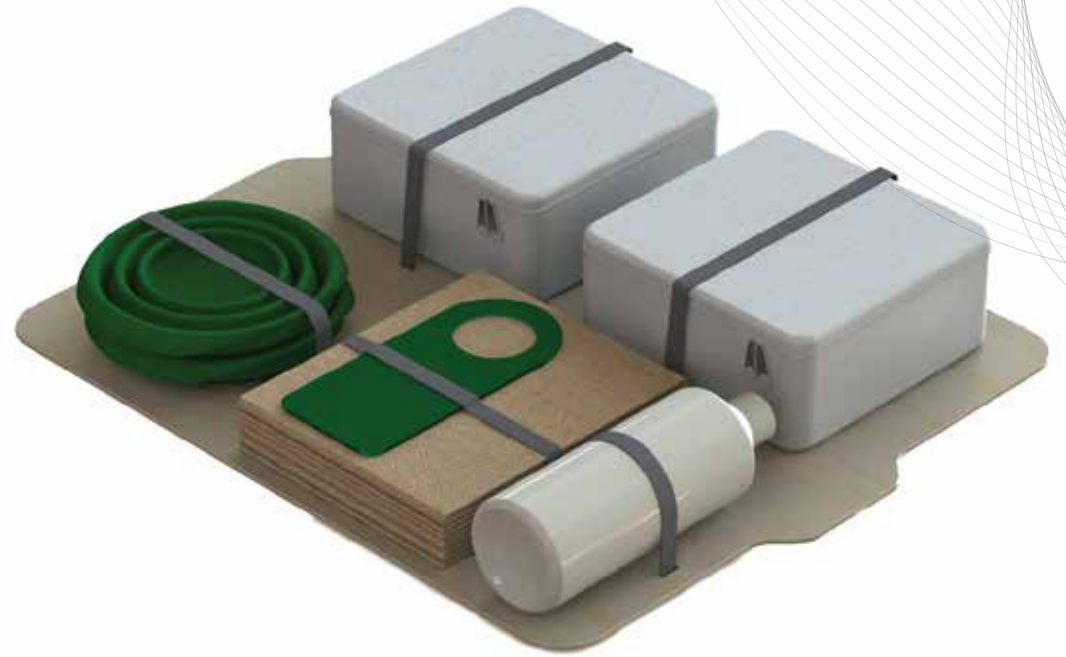

3D Rendering

# Previous Projects 3D Renders



# Previous Projects 3D Renders





## Quality Control and Assurance Services

C2W offer a range of inspection services to meet the needs of companies having goods manufactured in China. We understand the importance of ensuring production is checked throughout the manufacturing process. You can call on us for a single inspection or for a complete end-to-end service. We undertake initial factory capability audits, pre-production, final random sampling and pre-shipment inspections. We can also be on site to provide loading supervision. Whatever service you require, we will provide a written report with images if appropriate within 24 hours of completing the task.

One of the most important factors in the success of your project is the capability of the supplier. At C2W we only work with reputable factories that have passed our verification process. We assess factories on a wide range of factors including: equipment and systems, management, and operating procedures.

We can call on a broad spectrum of industries to meet the needs of most projects, but if you have found your own supplier, we can provide local 'eyes and ears' to oversee any stage of your production. Our inspection teams have experience in just about every manufacturing sector and can conduct detailed inspections to your specification.

We will examine (and test if appropriate) raw materials, semi-finished or finished products. Reports can be as detailed as you require, a typical pre-shipment report will cover product safety, quality, quantity, workmanship, function, colour, size, labeling and packing. Where testing is required, C2W uses internationally respected third party testing facilities and we will send you originals of all reports to ensure your product meets all country, industry, or otherwise-specified requirements.



# Quality Control Inspections & Audits

## Pre-Production Inspection (Supplier Audits)

Before placing an order with a new manufacturer it is important to ensure that quality specifications are fully understood, that the supplier has adequate production capability, machinery, staff training, on job supervision, working conditions, management systems and quality control processes in place to successfully complete the order. Pictures from the supplier website or a glossy brochure are often a far cry from the reality of the daily workings of the factory.

This process is customer driven and C2W will inspect against any specified customer requirements.

## Initial Production Check (IPC)

C2W can perform inspections throughout the production process. A critical step often over looked is during the very early stages of production (not more than 5% produced). All raw materials and components will be inspected to ensure all components meet pre-defined customer requirements. The initial output from production line will be checked against the approved sample and specification. C2W works with the factory in order to improve production processes and provide technical advice in order to improve the product quality to ensure the products will pass all future inspections.

To detect any potential defect, C2W will randomly select a number of semi-produced products for checking and report our findings for reference.

## During Production Inspection (DUPRO)

As soon as the first products come off the production lines, designated C2W inspection staff member will be on the factory floor to check for any defects or deviation from pre-defined quality parameters. If problems are identified practical and effective solutions will be offered.

During Production Inspection will be completed periodically at pre-defined periods. If a project is of high complexity or of significantly substantial quantity full time C2W factory representation can be allocated with a daily reporting structure.

An example standard inspection procedure would be completed at the following key production stages:

< 5% Produced,  
10-15% Produced  
40-50% Produced  
75% Produced  
90-100%.

If at any stage problems should occur, C2W identifies the deviation and provides advice on the corrective measures to get production back on track.

## General In-Process Quality Control (IPQC)

Understanding that machines and people cannot guarantee consistency of their performance and output is the point of in-process quality control. First Article Inspection (FAI) is conducted after the manufacturing system reaches 'optimum stability', not 'perfect stability' so further checks need to be made in order to ensure that any changes are both recognized and recorded. It is important that standards are clearly specified from the beginning so that those conducting IPQC can know when production has reached a critical point and needs to be stopped and corrected.

If a problem is detected, all parts produced in the same batch must be quarantined and re-checked 100%.

## Packing Inspection

Final product packaging is an important part of the production process. C2W QC engineers will oversee the packaging process to ensure all products are safely packaged as per requirements.

Specific packaging integrity testing (drop tests, compression tests, vibration testing etc.) can be arranged with our partner testing facilities on request.

## Pre-Shipment Inspection (PSI)

Pre-shipping inspection is critical for the final verification of a lot's quality status. As the manufacturing system already has several protective layers, PSI inspectors (ideally from a 3rd party such as C2W or our sister company Quality 2 West) need only check the goods based on an agreed AQL (Acceptable Quality Level). This determines the number of parts that should be checked and the number, and specific types of defects that are allowed within the lot.

If too many defective articles are found within the sample lot, the supplier must re-check or scrap all parts in stock and issue an 8D CAR (Corrective Action Report) within 4 days.

C2W Quality Inspectors use the MIL-STD-105E tables (also known as AQL tables) to measure acceptable levels of quality during their routine product inspections. These tables are a US military standard with equivalents in all national and international standardization organizations (ANSI/ASQC Z1.4, ISO 2859, NF06-022, BS 6001, DIN 40080).

The MIL-STD-105E sampling plan is a chart created by the US Army to determine the amount of parts that should be checked according to the size of the lot. The AQL (Acceptable Quality Level) can be set to an agreed figure for each type of defect that determines clearly the number of parts that are allowed to have certain types of defects before the entire lot is rejected and dealt with by the manufacturer.

## Container Loading Check (CLC)

C2W will co-ordinate with the Manufacturer to observe that the proper environmental conditions, cleanliness and integrity of the containers are adequate for the transport of the shipment to its final destination.

C2W will then oversee the entire loading process to ensure the correct ordered merchandise is loaded and sealed into the container.

The following information will be checked and recorded:

- Loaded quantity against the submitted packing list
- Container ID number and sealing code
- Form of packing
- Weather conditions
- Arrival/departure time of the container
- Photos of the inside and outside of the container and loading process
- The outer surface condition of the container and general condition of the truck for transportation purposes

Our strength lies in the abilities of our highly qualified and well trained quality engineers. You will be introduced directly to your allocated project manager who will oversee all facets of your inspection. Repeat inspections will be conducted by the same member of the C2W quality team ensuring you slowly develop your own on the ground expert in your specific products and field.

## Customized Production Review/Troubleshooting

C2W is ultimately flexible in its approach and we pride ourselves on our ability to customize our work to our specific customer requirements. Any and all of our internal documentation and processes can be adjusted to suit you, your product and the manufacturing facility in question.

When unforeseen issues occur we are always available for short notice factory troubleshooting reviews to get your production run back on track. On completion of a troubleshooting audit the C2W team will offer a full unbiased assessment along with detailed corrective action recommendations.

# Logistics & Distribution

C2W can provide total encompassing service arranging safe delivery to your door, anywhere in the world. Through our warehouses and partners in South China and the Bahamas we can offer a range of 3PL, consolidation and drop ship services tailored to your needs.

With our own full time logistics team, we can help you move freight by any available method to anywhere in the world. For a fee we can also assist in storage of over productions in China for a fraction of the cost of warehouse space in the west and distribute to you in batches as and when needed.



We have experience handling almost any kind of manufactured goods and shipping it to the world.



What you need. Where you need it. When you need it

## Other Services

Since our inception in 2005 we have seen and heard literally 100s of China horror stories and manufacturing nightmares, it's the reason why we have such a successful and growing company in China. We are the solution to these nightmares.

If you're already manufacturing in China or sourcing in China and have encountered issues that you need assistance with solving we can and will do all we can to help you.

C2W is ultimately flexible in its approach and we pride ourselves on our ability to customize our work to our specific customer requirements. Any and all of our internal documentation and processes can be adjusted to suit you, your product and the manufacturing facility in question.

When unforeseen issues occur we are always available for short notice factory troubleshooting reviews to get your production run back on track. On completion of a troubleshooting audit the C2W team will offer a full unbiased assessment along with detailed corrective action recommendations.

The directors' are constantly on the lookout for the next great idea. We're entrepreneurs at heart and business men in our heads this makes us very interested in everything and very savvy at choosing the right ones. If you have an idea that you would like to partner with us in China or abroad please get in touch and pitch us your idea, we'll be more than happy to hear it.



## Business Setup Services

C2W recommends Zhuhai city as the perfect place for western companies to set up a facility. Zhuhai is privileged as one of the only 5 SEZ (Special Economic Zones) in China and also has a special FTZ (Free Trade Zone) custom bonded industrial zone. The perfect location for your company depends on the products you wish to manufacture.

Zhuhai also benefits from a location inside the Pearl River Delta, China's largest manufacturing and industrial powerhouse. This means that virtually every sub-contractor you would ever need is likely to be within 1-2 hours drive of your own facility.

As a new city, the infrastructure in Zhuhai is excellent, with its own deep water port, airport and all the usual benefits of a large city.

Finally, Zhuhai is recognised as one of the cleanest and nicest cities in China meaning that staff recruitment and retention (both Chinese & Western) is never a problem. Furthermore, management staff and families are well served by first class accommodation and entertainment facilities.

C2W can help you through the whole process including location finding, site assessment, recruitment and all the necessary paperwork with the various government departments.

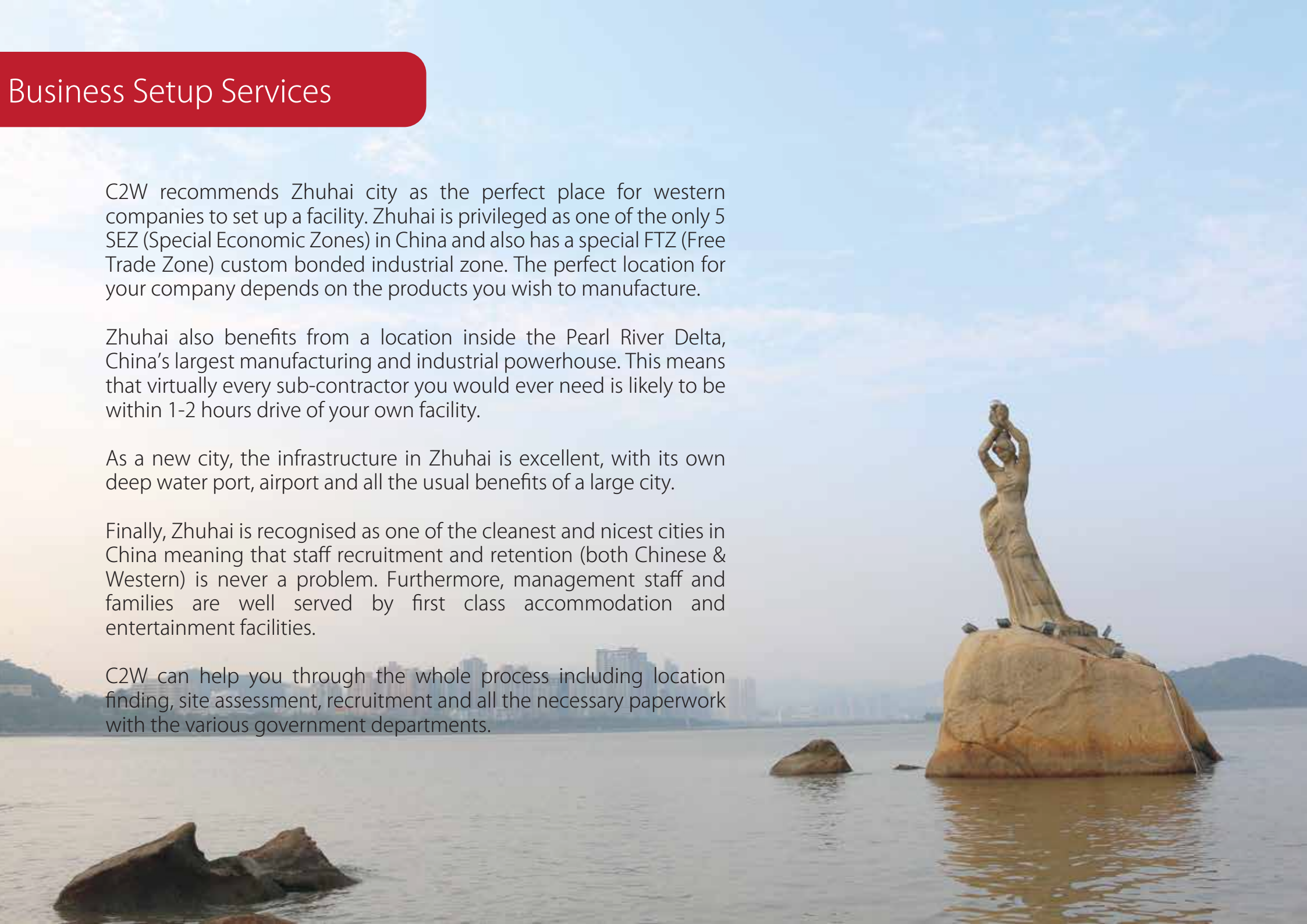



# C2W Global Distribution



# Who We Work with



# The C2W Group

C2W Group's businesses are founded on the concept of tier one quality services and innovative products at a competitive price.

From our foundations in HK in 2005 as a manufacturing consultancy we now have businesses in several different countries and in a diverse range of sectors including manufacturing, quality control, product design & development, bars & restaurants, watersports equipment, education, healthcare products, food distribution and telecommunications.

Within the group we currently have offices in 9 different countries with 7 offices in mainland China.

Our dedicated and passionate team work tirelessly across our business sectors as we continue to grow and to seek out new investment opportunities.

We are always looking for great people and for new challenges so do not hesitate to contact us if you would like to work for or partner with C2W Group.



**CHINA2WEST SERVICES™**  
Quality Manufacturing Solutions



**QUALITY2WEST+**  
...TAKE CONTROL



**C2W GROUP BUYING**



INTERNATIONAL FUTURES



**SimplyRoam.cn**  
Internet for travel



**THE LONDON  
LOUNGE**

**CITY OF ZHUHAI 伦敦廊**



**MAELSTORM**  
group

## The Companies



**The fastest growing quality control service provider in China.**

Our western-managed business ethics, flexibility and personal approach ensure you get much more than your typical third party inspection service. At Quality 2 West we pride ourselves on providing much more than your typical third party inspection service offering a truly personal approach individually tailored to meet your needs.

Experience the 'Q2W difference' and take control of your supply chain today.

[www.quality2west.com](http://www.quality2west.com)



**C2W GROUP BUYING**  
**Placing Product Where it Counts**

C2W GROUP BUYING (CGB), with its headquarters in the Bahamas, is a wholly owned subsidiary of the C2W GROUP. As the food purchasing organization of the Group, it is responsible for the international procurement of and importation of foodstuffs into the Caribbean and other surrounding nations.

Buying of foodstuffs is an essential element of wholesaling and retailing. Better prices are achieved by buying directly at source and through close collaboration with suppliers, CGB is always happy to pass on these cost savings to wholesalers and retailers in our areas allowing for more added value throughout the sales channel. Our rigorous quality control is established with actual testing of imported products and high quality minimum requirements.

At CGB, offering a wide variety of unbeatable products to our customers is always one of our main goals.

[www.c2wgroupbuying.com](http://www.c2wgroupbuying.com)



## The Companies



We offer a prepaid global data sim card, so that you can access the Internet wherever you go, at the cheapest roaming rates ever provided. Staying connected when abroad is notoriously expensive and difficult; data roaming with your home sim is extortionate, as well as the inconvenient search for WiFi hotspots, discourage a lot of people from using the Internet in a foreign country. This is all about to change with SimplyRoam.

We pride ourselves on providing a quality service giving travellers value, convenience and peace of mind.

We have built SimplyRoam to ensure that you will be able to stay connected, anywhere, with one sim card. We are committed to reducing the costs of overseas communication and making the process of doing this as simple and efficient as possible.

[www.simplyroam.cn](http://www.simplyroam.cn)



INTERNATIONAL FUTURES

International Futures (IF) is an elite specialist business English consultancy. We provide quality driven British English business training designed to not only teach you English but to also develop your career and increase your business' revenue.

Many business and English training centres in China claim to be 'international schools' despite being Chinese owned and managed. They might hire foreign teachers, but everything about their business philosophy is local.

From the way we manage staff, to the way we market ourselves, to the way we teach our students, everything is done in a truly international way.

This means that when you are in our English classes, you are not just learning from a foreign teacher, you are entering an entirely English environment. In effect, an IF classroom is like a trip to London.

[www.international-futures.com](http://www.international-futures.com)



## The Companies



Cambridge English Online is an elite specialist online English school. We provide high quality English lessons for an incredibly low price.

We are British owned and managed. Also all of our teachers are native English speakers. This means that when you are taking online English lessons, you are not just learning from a native English teacher, you are entering an entirely English environment. In effect a CEO classroom is like a trip to a native English speaking country like England or USA. This is unquestionably the best way to learn English.

[www.learn-english-ceo.com](http://www.learn-english-ceo.com)

## THE LONDON LOUNGE

CITY OF ZHUHAI 伦敦廊

The London Lounge is an authentic British bar and restaurant franchise located in the heart of Zhuhai. With two current Zhuhai locations The London Lounge aims to develop it's one of a kind food and beverage experience throughout China with an aggressive expansion plan.

[www.londonloungezhuhai.com](http://www.londonloungezhuhai.com)



Maelstorm-Gear kite surfing and watersports products are designed and developed in cooperation with the industries front line of instructors and school owners to deliver the best in function, rideability, and cost. Maelstorm-Gear's mission is to expand the family of riders, making kiting more affordable to everyone.

[www.maelstorm-gear.com](http://www.maelstorm-gear.com)







**CHINA<sup>2</sup>WEST SERVICES**™  
Quality Manufacturing Solutions

[www.china2west.com](http://www.china2west.com)  
[www.c2w-group.com](http://www.c2w-group.com)